



6234B-C 6234AB-C

SOFT SERVE FREEZER

2 Flavor, Countertop, Pasteurization
A: Pump Feed Model

Most **Compact & Versatile**
two-flavor table model with
Auto-Pasteurization and
intelligent controls

Auto-Pasteurization

Significantly reduces frequency of cleaning to every 21 days with scheduled daily auto-pasteurization

Digital Control and Display

Microprocessor control provides access to system settings and additional functions. Digital interface displays critical info as system status, temperatures, dispense count, errors, etc.

Operation Logging

Logs every operation and error to provide history and data for easy troubleshooting

Auto Programming

Allows automatic switching of operation modes based on preset schedules

Ideal for any restaurants, convenience stores, dessert stands and delis to serve ice cream and gelato. Small foot print and low energy consumption help reduce operating cost.



Hopper Agitators

Maintain product consistency and prevent product separation

Defrost for Cleaning

Increases efficiency during cleaning by heating frozen product in cylinder

Direct Drive Transmission

Eliminates consumable moving parts, significantly reduces noise and increases transmission efficiency

Safety Protections

- Low temperature and motor overload shutoffs to protect in the event of cylinder freeze up
- High pressure switch to prevent compressor overheating

Refresh and Revive

Restore perfect consistency automatically to reduce product waste and labor cost while ensuring food safety

Self Closing Valve with Speed Control

Automatically prevents product overflow after dispense; Provides flexibility in dispense rate control



6234B-C/6234AB-C

SOFT SERVE FREEZER

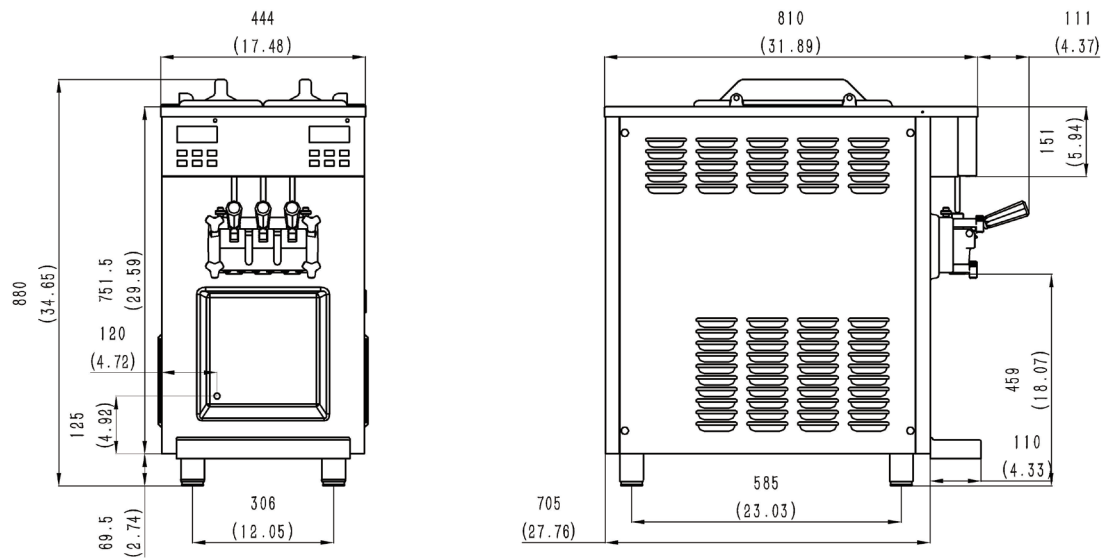

SPECIFICATIONS

Flavors	2 + Twist
Freezing Cylinders	2 x 1.2L / 1.3qt
Mix Hoppers	2 x 8.0L (5L for A)
Output Capacity (80 grams)	280 serves/hr
Clearance Requirements	152mm/6" on back

Weight

	Kg/lb (Gravity)	Kg/lb (Pump)
Net	135 / 298	145 / 320
Shipping	150 / 331	160 / 353

Volume 0.48 CBM / 16.78 CBF

Dimensions

	Net (mm/in)	Shipping (mm/in)
Width	444 / 17.5	530 / 20.9
Depth	705 / 27.8	830 / 32.7
Height	880 / 34.6	1080 / 42.5

Electrical

	Power (kW)	Total Amps (A)	Fuse (A)
220-240/50/1	2.8	14	20
208-230/60/1	3.0	15	30

FEATURES

Control Systems	Double, Digital
Refrigerated Hoppers	✓
Hopper Agitators	✓
Temperature Display	✓
Standby Mode	✓
Auto Closing Dispensing Valves	✓
Dispensing Speed Control	✓
Low Mix Indicator Light & Alarm	✓
Low Temperature Protection	✓
Motor Overload Protection	✓
High Pressure Protection	✓
Defrost & Refresh	✓
Soft Start	✓
Direct Drive Pumps	✓
Auto-Pasteurization	✓

AVAILABLE OPTIONS

Top Air Discharge Chute	✓
-------------------------	---

• Above specifications are subject to change without notice